

**Warewashing
 green&clean dual rinse rack type
 dishwasher, 250racks/hour, electric,
 50Hz**

ITEM # _____

MODEL # _____

NAME # _____

SIS # _____

AIA # _____

CC0FVP (CC0FVP)

 Dual rinse rack type
 dishwasher, 250racks/hour,
 CLEAR BLUE Filtering
 System, electric, touch
 screen, customized direction
 on-site, 50Hz

Short Form Specification

Item No. _____

Unit to be dual rinse rack type dishwasher. Dual rinse with built-in stabilized pressure valve ensures the right rinsing pressure for optimum hygiene results. Maximum Water Contact (MWC) wash arms are positioned along the full length of the wash tank. Included large pre-wash zone works with cold water of maximum 40°C. Powerful wash pump and specially designed wash spray arms guarantee cleaning. Washing is done with water circulating at 55-65° C. Final rinsing is done with clean water heated up to 85°C. Dual rinse technology provides rinse water covering maximum the rinse area to ensure hygiene on washed wares. Low rinse water consumption of 1.0 liters per rack at maximum speed of 250racks/hour. Three conveyor speeds are selectable by the operator with maximum capacity of 250racks/hour. Intuitive touch screen control panel provides easy communication on different levels. Large counter-balance door has heat and noise insulation with easy internal access. CLEAR BLUE filtering system removes majority of soil from the wash water to ensure clean water for long time. Built-in drain valve in the tank allows automatic dump and fill to refresh the water in the tank without interruption. Standard end of the day self cleaning cycle and sanitation cycle. Operating direction of the machine is decided by customer on-site depending on the layout flow with pre-arranged right to left from the factory.

Main Features

- Adjustable feet for full access underneath the machine for cleaning.
- IP25 protection against water jets, solid objects and small animals (larger than 6 mm).
- Built-in drain valve in the tanks allows automatic dump and fill to refresh the water in the tank without any interruption of the washing process.
- CLEAR BLUE filtering system removes soil from the wash water providing cleaner water and highly active detergent thus ensuring better washing performance and lower running costs.
- Pre-wash section uses cold water so food remains are not "baked" onto the plates in order to have better pre-wash performance.
- Intuitive touch screen control panel features user-friendly display to easily operate the machine and to monitor machine status. Three different levels of interaction are available each show relevant messages and information to the operator, the general maintenance staff and the authorized service partners.
- All internal components: wash and rinse arms, tank filters, curtains can be easily removed for cleaning.
- Unit equipped with USB port making it simple to read data such as machine identification, counters and consumption, components, devices and alarm logs. Machine parameters can be uploaded and downloaded and firmware updated.
- Large counter balanced inspection door allow unrestricted all-round access to the wash and rinse area. Door is insulated with injected foam. This adds strength as well as reduces noise and heat loss.
- Automatic drain, clean and sanitize cycles featured as standard. The internal chamber, is completely cleaned or sanitized avoiding bacteria proliferation for maximum hygiene and reducing manual work/time for operator.
- Dual rinse technology ensures maximum rinse water covering every corner of the rack inside the rinse area for perfect hygiene on washed wares.
- Three conveyor speeds can be selected through the control panel by the operator and customized on-site.
- The unit is ready to be connected with OnE Connectivity for 24/7 real time monitoring, increasing equipment uptime, maximum profit and optimizing your process.
- Maximum capacity per hour of 250 racks easy to switch to DIN 10510 compliant or other speed.

Construction

- Deep drawn pressed wash tank with fully rounded corners, sloped towards the drain to prevent dirt buildup, provides fast drainage in just a few minutes. With no welding points the pressed tank offers a guaranteed water tight solution.
- Dishwasher structure is held together with a solid 50 x 50 mm stainless steel frame to provide long-term sturdiness.
- All electric components are put in one IP65 central box isolated from water and steam to ensure high

APPROVAL: _____

reliability.

- External pre-arrangement for inlet water, drain water, detergent & rinse aid connections for fast and easy installation on both sides of the unit.
- All main components made in heavy duty anti-corrosive 304 type stainless steel: external front, side panels and internal chambers, wash and rinse arms, doors and rack transportation system.
- Modularity design allows the machine not only be disassembled for delivery and re-assembled at customer's site, but also to be customized and upgraded on-site and over time.

Sustainability



- All chambers without internal pipes and therefore no hidden dirt traps.
- Auto-start/stop equipped in different zones ensures that the zone runs only when a rack is passing through it. This reduces water, energy, chemical consumption and noise.
- Built-in stabilized pressure valve ensures constant pressure throughout the rinsing cycle regardless of inlet water pressure.
- Self-draining vertical wash pumps provide maximum hygiene.
- Automatic back-up mode is activated when a failure occurs. Guided troubleshooting for fast fixes including 150 precises notifications and 23 easy-to-follow processes.
- Dual rinse with stabilized pressure valve guarantees rinse water consumption of 0.9 liters/ rack regardless of inlet water pressure to ensure low energy, water, detergent and rinse aid consumption.

Optional Accessories

- | | | |
|--|------------|--------------------------|
| • Medium drying zone with door for green&clean Dual Rinse Rack Type Dishwasher | PNC 535097 | <input type="checkbox"/> |
| • Large drying zone with door for green&clean Dual Rinse Rack Type Dishwasher | PNC 535098 | <input type="checkbox"/> |
| • Corner drying zone for green&clean Dual Rinse Rack Type Dishwasher | PNC 535099 | <input type="checkbox"/> |
| • Emergency stop kit for Rack Type Dishwasher (not for Basic handling system) | PNC 865162 | <input type="checkbox"/> |
| • End limit switch for short roller conveyor | PNC 865218 | <input type="checkbox"/> |
| • Connection bracket for plain undershelf and grid undershelf (to be used if roller conveyor is connected directly to Rack Type Dishwasher with splash hood) | PNC 865235 | <input type="checkbox"/> |
| • End limit switch for long roller conveyor (kit with two short rollers and end switch) | PNC 865256 | <input type="checkbox"/> |
| • Kit water softener for Rack Type dishwasher | PNC 865284 | <input type="checkbox"/> |
| • Kit water meter | PNC 865286 | <input type="checkbox"/> |
| • HACCP cable connection for Rack Type dishwasher | PNC 865490 | <input type="checkbox"/> |
| • Kit water softener and reverse osmosis for Rack Type Dishwasher | PNC 865494 | <input type="checkbox"/> |
| • Splash hood kit for single and dual rinse Rack Type Dishwasher, 200 mm | PNC 865498 | <input type="checkbox"/> |
| • Silicon curtains for single and dual rinse Rack Type dishwasher | PNC 865503 | <input type="checkbox"/> |
| • Kit delime & door cleaning for dual for Rinse Rack Rack Type Dishwasher | PNC 865507 | <input type="checkbox"/> |
| • Kit electronic connection for motorized table and remote pre wash module for Dual Rinse Rack Type Dishwasher | PNC 865508 | <input type="checkbox"/> |
| • Set of 6 baskets: 2 for trays, 2 for plates, 1 for cutlery and 1 for cups | PNC 867050 | <input type="checkbox"/> |
| • Set of 9 baskets: 2 for trays, 3 for plates, 2 for cutlery and 2 for cups | PNC 867051 | <input type="checkbox"/> |

Components

- 1 OF **534061** (EDR150EC5) Dual rinse rack type dishwasher, 150 racks/hour, CLEAR BLUE Filtering System, electric, touch screen, customized direction on-site, 50Hz
 - Shipping weight: 239 kg
 - Shipping height: 1950 mm
 - Shipping width: 1010 mm
 - Shipping depth: 1260 mm
 - Shipping volume: 2.48 m³
 - Current consumption: 0 Amps
- 1 OF **535096** (NLPWDRE) Large pre-wash zone for green&clean Dual Rinse Rack Type Dishwasher
 - Shipping weight: 157 kg
 - Shipping height: 2030 mm
 - Shipping width: 910 mm
 - Shipping depth: 1030 mm
 - Shipping volume: 1.9 m³
 - Current consumption: 0 Amps
- 1 OF **865506** (KITEBDR) Kit electronic board for Dual Rinse Rack Type Dishwasher
 - Shipping weight: 0.65 kg
 - Shipping height: 110 mm
 - Shipping width: 290 mm
 - Shipping depth: 190 mm
 - Shipping volume: 0.01 m³
 - Current consumption: 0 Amps



Electrolux
PROFESSIONAL

Warewashing
green&clean dual rinse rack type
dishwasher, 250racks/hour, electric, 50Hz

Front

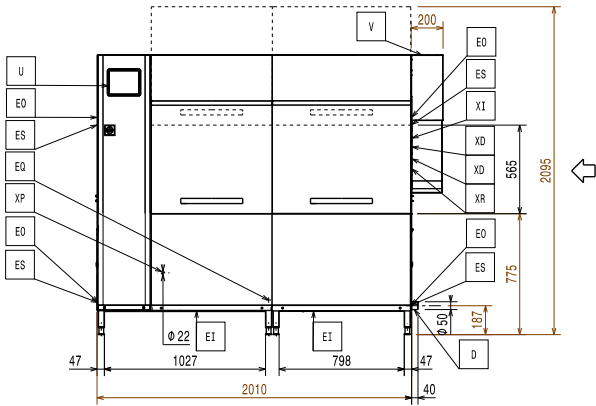

Side

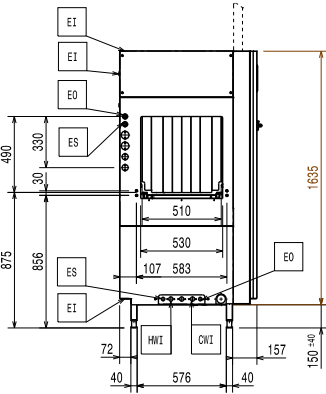

- CWI = Cold Water Inlet
- D = Drain
- EI = Electrical inlet (power)
- EO = Electrical Outlet
- EQ = Equipotential screw
- ES = Electrical signal IN/OUT
- HWI = Hot water inlet
- U = USB port
- WI = Water inlet

Top

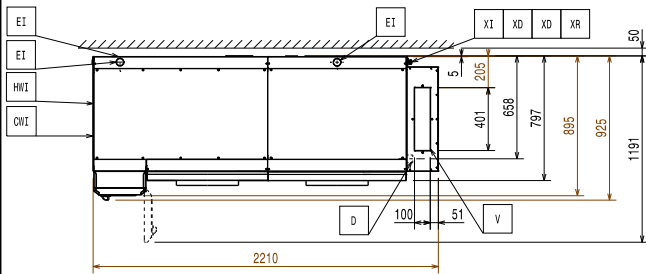

Front

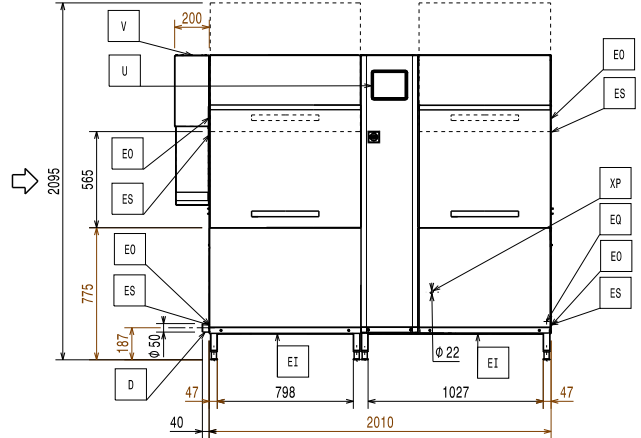

Side

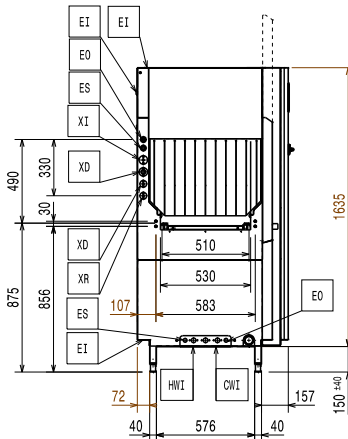

- CWI = Cold Water Inlet
- D = Drain
- EI = Electrical inlet (power)
- EO = Electrical Outlet
- EQ = Equipotential screw
- ES = Electrical signal IN/OUT
- HWI = Hot water inlet
- U = USB port
- WI = Water inlet

Top

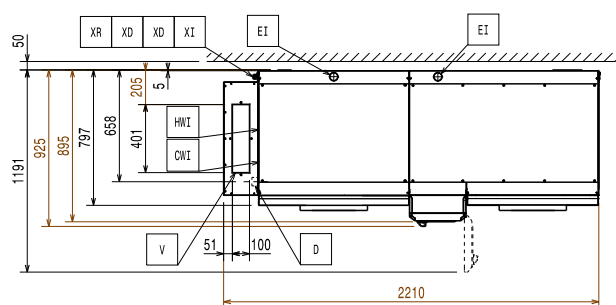



Electric

When the machine is run at DIN 10510 compliant speed.
Pre-wash tank heating element are activated only during sanitation cycle.

Wash pump size:	1.5kW
Supply voltage:	380-415 V/3N ph/50 Hz
Pre-wash tank heating elements:	7 kW
Default Installed Power:	28.5 kW
Boiler heating elements:	15 kW
Pre-wash pump size:	1,2 kW
Electrical power, min:	18.5 kW
Wash pump size:	1,2 kW
Wash tank heating elements:	10 kW

Water:

Inlet cold water line size:	G 3/4"
Inlet water supply temperature, pre-wash:	10-30°C
When below 7°F/4°dH special detergent and rinse aid are needed.	
Peak rate of drain flow:	2.5 l/s
Pre-wash tank size:	35 l
Wash tank size:	70 l
Inlet hot water line size:	G 3/4"
Drain line size:	50mm
Inlet water supply pressure:	1.5-6 bar
Inlet water supply temperature (wash and rinse):	50 - 65°C
Inlet water supply hardness:	14 °fH / 8°dH
Rinse water consumption:	250 l/h

Key Information:

For transportation purpose only, the depth can be reduced to either 895mm by removing the main switch button or 797mm by removing the control box and the door handle.

Reference norm used to measure the noise: IEC60335-2-58 annex AA.

Height with door open:	2095 mm
Charging hole size (width):	530 mm
Rinse temperature:	85 °C
Productivity per hour (max. speed):	250 racks/4500dishes
Productivity per hour (medium speed):	168 racks/3024 dishes
External dimensions, Width:	2210 mm
External dimensions, Depth:	925 mm
External dimensions, Height:	1785 mm
Productivity per hour (DIN compliant speed):	115 racks/2070 dishes
Charging hole size (height):	490 mm
Table to table distance:	2210 mm
Pre-wash temperature:	10-40°C
Wash temperature:	55 - 65 °C

Air Emission:

Air temperature:	27 °C
CC0FVP (CC0FVP)	27 °C
Air humidity (entrance, exit):	
CC0FVP (CC0FVP)	100 / 100 % r.h.
Latent heat:	5300 W
Sensible heat:	3900 W
Air flow (entrance, exit):	86 / 107 m³/h

The data is measured at exhaust points at 25°C and 60% r.h. ambient conditions, 18°C inlet water temperature and refer only to the machine.

This model requires a ventilation hood. Please refer to the attached "Recommended Exhaust Hood Design".

Sustainability

Rinse water consumption at max speed: 1 l/rack

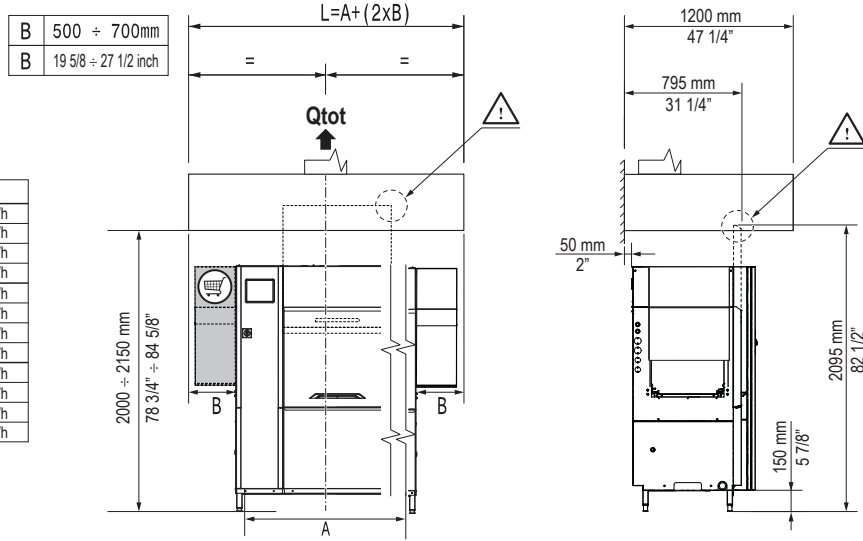
RECOMMENDED HOOD DESIGN OPTIONS

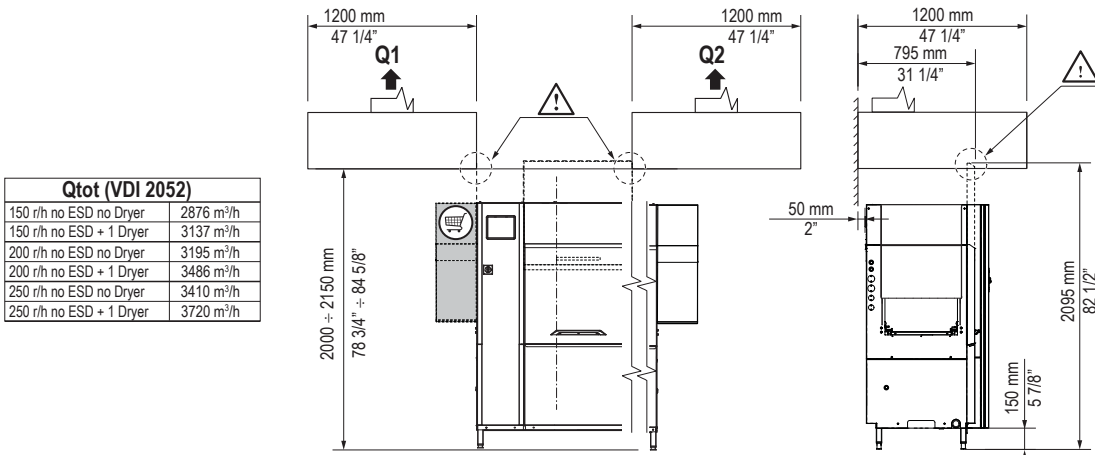

Q _{tot} (VDI 2052)	
150 r/h no ESD no Dryer	2876 m ³ /h
150 r/h ESD no Dryer	1468 m ³ /h
150 r/h no ESD + 1 Dryer	3137 m ³ /h
150 r/h ESD + 1 Dryer	1600 m ³ /h
200 r/h no ESD no Dryer	3195 m ³ /h
200 r/h no ESD no Dryer	1665 m ³ /h
200 r/h no ESD + 1 Dryer	3486 m ³ /h
200 r/h ESD + 1 Dryer	1817 m ³ /h
250 r/h no ESD no Dryer	3410 m ³ /h
250 r/h ESD no Dryer	1795 m ³ /h
250 r/h no ESD + 1 Dryer	3720 m ³ /h
250 r/h ESD + 1 Dryer	1958 m ³ /h

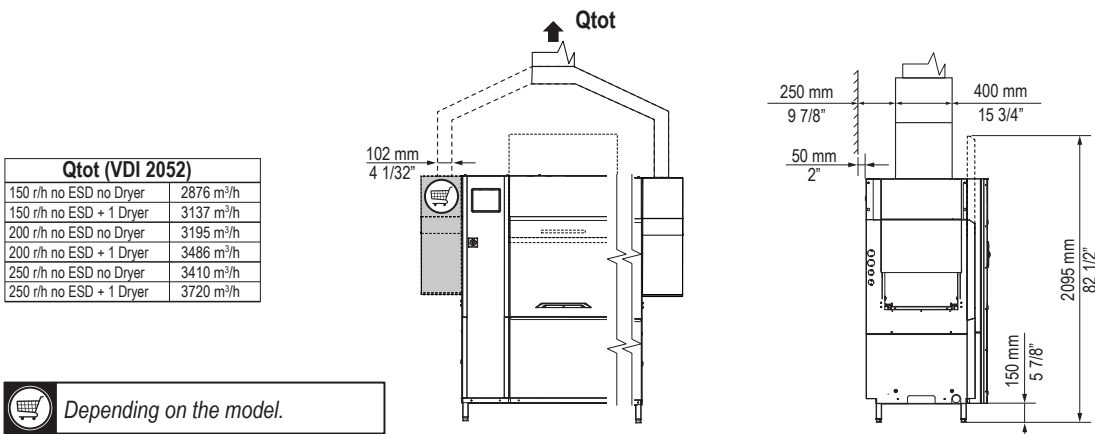

Q _{tot} (VDI 2052)	
150 r/h no ESD no Dryer	2876 m ³ /h
150 r/h no ESD + 1 Dryer	3137 m ³ /h
200 r/h no ESD no Dryer	3195 m ³ /h
200 r/h no ESD + 1 Dryer	3486 m ³ /h
250 r/h no ESD no Dryer	3410 m ³ /h
250 r/h no ESD + 1 Dryer	3720 m ³ /h



Q _{tot} (VDI 2052)	
150 r/h no ESD no Dryer	2876 m ³ /h
150 r/h no ESD + 1 Dryer	3137 m ³ /h
200 r/h no ESD no Dryer	3195 m ³ /h
200 r/h no ESD + 1 Dryer	3486 m ³ /h
250 r/h no ESD no Dryer	3410 m ³ /h
250 r/h no ESD + 1 Dryer	3720 m ³ /h

 Depending on the model.

All exhaust hoods must be dimensioned and installed according to local regulations and industry standards which may differ from the recommendations herein suggested. Electrolux Professional is not liable for any failure in complying with local design standards.

DOC. NO. 59566TD00
 EDITION 03.2022